



Main Features:-

- ◆ Butterfly Sanitary Valve
- ◆ Welding/Threaded ends
- ◆ Max. Working Pressure 10bar*
- ◆ Max. Working Temperature 120C *
- ◆ Body AISI 304, EPDM Seat

*Temperature and pressure determined by valve body, seat etc.

Suitable Applications & Approvals:



HVAC



OIL



GAS



INDUSTRY



SERIES: 80112

MANUFACTURER: **GENEBRE**

VALVE MATERIALS/DIMENSIONS

ITEM	SECTION	MATERIAL	ADDITIONAL INFO / OPTIONS
1	Body	SS 304	Mechanical Polish
2	Seat	EPDM	Spare Part Code: E2941
3	Disc	SS 304	Mechanical Polish
4	Handle	SS 304	-
5	Cap	Plastic	-
6	Bolt	SS 304	-
7	Nut	SS 304	-

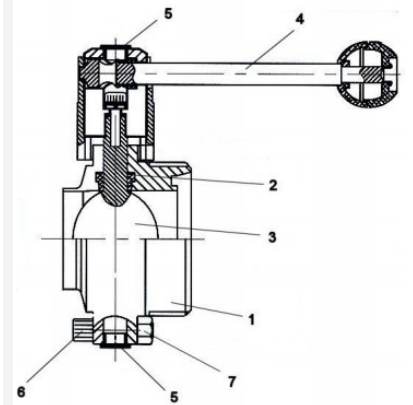

REF	Size	DN	L	D	t	H	L1	KxK	G	Kg
80112-06	1"	28	58	78	1.5	84	126	8x8	52x1/6"	1.28
80112-07	1 1/4"	31	60	86	1.5	88	126	8x8	58x1/6"	1.25
80112-08	1 1/2"	37	62	90	1.5	90	126	8x8	65x1/6"	1.48
80112-09	2"	49	64	106	1.5	101	133	10x10	78x1/6"	2.08
80112-10	2 1/2"	66	70	124	2	110	144	10x10	95x1/6"	2.7
80112-11	3"	81	75	139	2	121	160	11x11	110x1/4"	3.15
80112-12	4"	100	86	159	2	129	160	11x11	130x1/4"	4.25

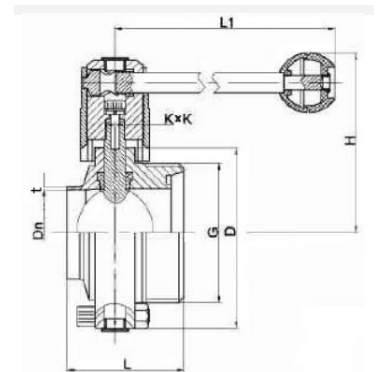

DN	100°	90°	80°	70°	60°	50°	40°	30°	20°	10°
25	19.8	14	12	11	8	6	5	4	2	1
32	35	28	21	17	12	10	7	4.5	2	1
40	48.5	40	32	24	20	11	9	5	4	1
50	91	75	61	48	34	24	15	10	5	1
65	142	95	90	80	54	35	30	14	6	4
80	205	150	100	95	86	60	40	21	11	5
100	372	340	290	250	195	140	75	38	25	10



T +44 (0)1386 552369

E sales@allvalves.co.uk

W www.allvalves.co.uk

F +44 (0)1386 554227